

28529

13" Two-Speed Finishing Planer

THIS MACHINE IS OWNED BY I3

(Model 22-580)



INSTRUCTION MANUAL

PART NO. A05724 - 05-20-05
Copyright © 2005 Delta Machinery

 **DELTA[®] INDUSTRIAL**

To learn more about DELTA MACHINERY
visit our website at: www.deltamachinery.com.

For Parts, Service, Warranty or other Assistance,

please call **1-800-223-7278** (In Canada call **1-800-463-3582**).

RTD10000122AA

TABLE OF CONTENTS

IMPORTANT SAFETY INSTRUCTIONS2
SAFETY GUIDELINES3
GENERAL SAFETY RULES4
ADDITIONAL SPECIFIC SAFETY RULES5
FUNCTIONAL DESCRIPTION7
CARTON CONTENTS8
ASSEMBLY8
OPERATION10
TROUBLESHOOTING15
MAINTENANCE16
SERVICE19
ACCESSORIES19
WARRANTY20
ESPAÑOL21
SERVICE CENTER LOCATIONSback cover

IMPORTANT SAFETY INSTRUCTIONS

▲ WARNING Read and understand all warnings and operating instructions before using any tool or equipment. When using tools or equipment, basic safety precautions should always be followed to reduce the risk of personal injury. Improper operation, maintenance or modification of tools or equipment could result in serious injury and property damage. There are certain applications for which tools and equipment are designed. Delta Machinery strongly recommends that this product NOT be modified and/or used for any application other than for which it was designed.

If you have any questions relative to its application DO NOT use the product until you have written Delta Machinery and we have advised you.

Online contact form at www.deltamachinery.com

Postal Mail: Technical Service Manager
Delta Machinery
4825 Highway 45 North
Jackson, TN 38305

(IN CANADA: 125 Mural St. Suite 300, Richmond Hill, ON, L4B 1M4)

Information regarding the safe and proper operation of this tool is available from the following sources:

Power Tool Institute
1300 Sumner Avenue, Cleveland, OH 44115-2851
www.powertoolinstitute.org

National Safety Council
1121 Spring Lake Drive, Itasca, IL 60143-3201

American National Standards Institute, 25 West 43rd Street, 4 floor, New York, NY 10036 www.ansi.org
ANSI 01.1 Safety Requirements for Woodworking Machines, and

the U.S. Department of Labor regulations www.osha.gov

SAVE THESE INSTRUCTIONS!

GENERAL SAFETY RULES



⚠ WARNING READ AND UNDERSTAND ALL WARNINGS AND OPERATING INSTRUCTIONS BEFORE USING THIS EQUIPMENT. Failure to follow all instructions listed below, may result in electric shock, fire, and/or serious personal injury or property damage.

IMPORTANT SAFETY INSTRUCTIONS

- FOR YOUR OWN SAFETY, READ THE INSTRUCTION MANUAL BEFORE OPERATING THE MACHINE.** Learning the machine's application, limitations, and specific hazards will greatly minimize the possibility of accidents and injury.
- WEAR EYE AND HEARING PROTECTION. ALWAYS USE SAFETY GLASSES.** Everyday eyeglasses are NOT safety glasses. USE CERTIFIED SAFETY EQUIPMENT. Eye protection equipment should comply with ANSI Z87.1 standards. Hearing equipment should comply with ANSI S3.19 standards.
- WEAR PROPER APPAREL.** Do not wear loose clothing, gloves, neckties, rings, bracelets, or other jewelry which may get caught in moving parts. Nonslip footwear is recommended. Wear protective hair covering to contain long hair.
- DO NOT USE THE MACHINE IN A DANGEROUS ENVIRONMENT.** The use of power tools in damp or wet locations or in rain can cause shock or electrocution. Keep your work area well-lit to prevent tripping or placing arms, hands, and fingers in danger.
- MAINTAIN ALL TOOLS AND MACHINES IN PEAK CONDITION.** Keep tools sharp and clean for best and safest performance. Follow instructions for lubricating and changing accessories. Poorly maintained tools and machines can further damage the tool or machine and/or cause injury.
- CHECK FOR DAMAGED PARTS.** Before using the machine, check for any damaged parts. Check for alignment of moving parts, binding of moving parts, breakage of parts, and any other conditions that may affect its operation. A guard or any other part that is damaged **should be properly repaired or replaced.** Damaged parts can cause further damage to the machine and/or injury.
- KEEP THE WORK AREA CLEAN.** Cluttered areas and benches invite accidents.
- KEEP CHILDREN AND VISITORS AWAY.** Your shop is a potentially dangerous environment. Children and visitors can be injured.
- REDUCE THE RISK OF UNINTENTIONAL STARTING.** Make sure that the switch is in the "OFF" position before plugging in the power cord. In the event of a power failure, move the switch to the "OFF" position. An accidental start-up can cause injury.
- USE THE GUARDS.** Check to see that all guards are in place, secured, and working correctly to reduce the risk of injury.
- REMOVE ADJUSTING KEYS AND WRENCHES BEFORE STARTING THE MACHINE.** Tools, scrap pieces, and other debris can be thrown at high speed, causing injury.
- USE THE RIGHT MACHINE.** Don't force a machine or an attachment to do a job for which it was not designed. Damage to the machine and/or injury may result.
- USE RECOMMENDED ACCESSORIES.** The use of accessories and attachments not recommended by Delta may cause damage to the machine or injury to the user.
- USE THE PROPER EXTENSION CORD.** Make sure your extension cord is in good condition. When using an extension cord, be sure to use one heavy enough to carry the current your product will draw. An undersized cord will cause a drop in line voltage, resulting in loss of power and overheating. See the Extension Cord Chart for the correct size depending on the cord length and nameplate ampere rating. If in doubt, use the next heavier gauge. The smaller the gauge number, the heavier the cord.
- SECURE THE WORKPIECE.** Use clamps or a vise to hold the workpiece when practical. Loss of control of a workpiece can cause injury.
- FEED THE WORKPIECE AGAINST THE DIRECTION OF THE ROTATION OF THE BLADE, CUTTER, OR ABRASIVE SURFACE.** Feeding it from the other direction will cause the workpiece to be thrown out at high speed.
- DON'T FORCE THE WORKPIECE ON THE MACHINE.** Damage to the machine and/or injury may result.
- DON'T OVERREACH.** Loss of balance can make you fall into a working machine, causing injury.
- NEVER STAND ON THE MACHINE.** Injury could occur if the tool tips, or if you accidentally contact the cutting tool.
- NEVER LEAVE THE MACHINE RUNNING UNATTENDED. TURN THE POWER OFF.** Don't leave the machine until it comes to a complete stop. A child or visitor could be injured.
- TURN THE MACHINE "OFF", AND DISCONNECT THE MACHINE FROM THE POWER SOURCE** before installing or removing accessories, before adjusting or changing set-ups, or when making repairs. An accidental start-up can cause injury.
- MAKE YOUR WORKSHOP CHILDPROOF WITH PADLOCKS, MASTER SWITCHES, OR BY REMOVING STARTER KEYS.** The accidental start-up of a machine by a child or visitor could cause injury.
- STAY ALERT, WATCH WHAT YOU ARE DOING, AND USE COMMON SENSE. DO NOT USE THE MACHINE WHEN YOU ARE TIRED OR UNDER THE INFLUENCE OF DRUGS, ALCOHOL, OR MEDICATION.** A moment of inattention while operating power tools may result in injury.
- ⚠ WARNING** USE OF THIS TOOL CAN GENERATE AND DISBURSE DUST OR OTHER AIRBORNE PARTICLES, INCLUDING WOOD DUST, CRYSTALLINE SILICA DUST AND ASBESTOS DUST. Direct particles away from face and body. Always operate tool in well ventilated area and provide for proper dust removal. Use dust collection system wherever possible. Exposure to the dust may cause serious and permanent respiratory or other injury, including silicosis (a serious lung disease), cancer, and death. Avoid breathing the dust, and avoid prolonged contact with dust. Allowing dust to get into your mouth or eyes, or lay on your skin may promote absorption of harmful material. Always use properly fitting NIOSH/OSHA approved respiratory protection appropriate for the dust exposure, and wash exposed areas with soap and water.

ADDITIONAL SPECIFIC SAFETY RULES

⚠ WARNING FAILURE TO FOLLOW THESE RULES MAY RESULT IN SERIOUS INJURY.

1. **DO NOT OPERATE THIS MACHINE** until it is completely assembled and installed according to the instructions. A machine incorrectly assembled can cause serious injury.
2. **OBTAIN ADVICE** from your supervisor, instructor, or another qualified person if you are not thoroughly familiar with the operation of this machine. Knowledge is safety.
3. **FOLLOW ALL WIRING CODES** and recommended electrical connections to prevent shock or electrocution.
4. **KEEP KNIVES SHARP** and free from rust and pitch. Dull or rusted knives work harder and can cause kickback.
5. **NEVER TURN THE MACHINE “ON”** before clearing the table of all objects (tools, scraps of wood, etc.). Flying debris can cause serious injury.
6. **NEVER TURN THE MACHINE “ON”** with the workpiece contacting the cutterhead. Kickback can occur.
7. **SECURE THE MACHINE TO A SUPPORTING SURFACE** to prevent the machine from sliding, walking or tipping over.
8. **PROPERLY SECURE THE KNIVES IN THE CUTTERHEAD** before turning the power “ON”. Loose blades may be thrown out at high speeds causing serious injury.
9. **LOCK THE SPEED SETTING SECURELY** before feeding the workpiece through the machine. Changing speeds while planing can cause kickback.
10. **AVOID AWKWARD OPERATIONS AND HAND POSITIONS.** A sudden slip could cause a hand to move into the knives.
11. **KEEP ARMS, HANDS, AND FINGERS** away from the cutterhead, the chip exhaust opening, and the feed rollers to prevent severe cuts.
12. **NEVER REACH INTO THE CUTTERHEAD AREA** while the machine is running. Your hands can be drawn into the knives.
13. **DO NOT STAND IN LINE OF THE WORKPIECE.** Kickback can cause injury.
14. **ALLOW THE CUTTERHEAD TO REACH FULL SPEED** before feeding a workpiece. Changing speeds while planing can cause kickback.
15. **WHEN PLANING BOWED STOCK,** place the concave (cup down) side of the stock on the table and cut with the grain to prevent kickback.
16. **DO NOT FEED A WORKPIECE** that is warped, contains knots, or is embedded with foreign objects (nails, staples, etc.). Kickback can occur.
17. **DO NOT FEED A SHORT, THIN, OR NARROW WORKPIECE INTO THE MACHINE.** Your hands can be drawn into the knives and/or the workpiece can be thrown at high speeds. See the “OPERATION” section of this instruction manual for details.
18. **DO NOT FEED A WORKPIECE** into the outfeed end of the machine. The workpiece will be thrown out of the opposite side at high speeds.
19. **REMOVE SHAVINGS ONLY** with the power “OFF” to prevent serious injury.
20. **PROPERLY SUPPORT LONG OR WIDE WORKPIECES.** Loss of control of the workpiece can cause serious injury.
21. **NEVER PERFORM LAYOUT, ASSEMBLY** or set-up work on the table/work area when the machine is running. Serious injury will result.
22. **TURN THE MACHINE “OFF”, DISCONNECT IT FROM THE POWER SOURCE,** and clean the table/work area before leaving the machine. **LOCK THE SWITCH IN THE “OFF” POSITION** to prevent unauthorized use. Someone else might accidentally start the machine and cause injury to themselves or others.
23. **ADDITIONAL INFORMATION** regarding the safe and proper operation of power tools (i.e. a safety video) is available from the Power Tool Institute, 1300 Sumner Avenue, Cleveland, OH 44115-2851 (www.powertoolinstitute.com). Information is also available from the National Safety Council, 1121 Spring Lake Drive, Itasca, IL 60143-3201. Please refer to the American National Standards Institute ANSI 01.1 Safety Requirements for Woodworking Machines and the U.S. Department of Labor Regulations.

**SAVE THESE INSTRUCTIONS.
Refer to them often
and use them to instruct others.**

POWER CONNECTIONS

A separate electrical circuit should be used for your machines. This circuit should not be less than #12 wire and should be protected with a 20 Amp time lag fuse. If an extension cord is used, use only 3-wire extension cords which have 3-prong grounding type plugs and matching receptacle which will accept the machine's plug. Before connecting the machine to the power line, make sure the switch (s) is in the "OFF" position and be sure that the electric current is of the same characteristics as indicated on the machine. All line connections should make good contact. Running on low voltage will damage the machine.

⚠ DANGER DO NOT EXPOSE THE MACHINE TO RAIN OR OPERATE THE MACHINE IN DAMP LOCATIONS.

MOTOR SPECIFICATIONS

Your machine is wired for 120 V., 60 HZ alternating current. Before connecting the machine to the power source, make sure the switch is in the "OFF" position.

GROUNDING INSTRUCTIONS

⚠ DANGER THIS MACHINE MUST BE GROUNDED WHILE IN USE TO PROTECT THE OPERATOR FROM ELECTRIC SHOCK

1. All grounded, cord-connected machines:

In the event of a malfunction or breakdown, grounding provides a path of least resistance for electric current to reduce the risk of electric shock. This machine is equipped with an electric cord having an equipment-grounding conductor and a grounding plug. The plug must be plugged into a matching outlet that is properly installed and grounded in accordance with all local codes and ordinances.

Do not modify the plug provided - if it will not fit the outlet, have the proper outlet installed by a qualified electrician.

Improper connection of the equipment-grounding conductor can result in risk of electric shock. The conductor with insulation having an outer surface that is green with or without yellow stripes is the equipment-grounding conductor. If repair or replacement of the electric cord or plug is necessary, do not connect the equipment-grounding conductor to a live terminal.

Check with a qualified electrician or service personnel if the grounding instructions are not completely understood, or if in doubt as to whether the machine is properly grounded.

Use only 3-wire extension cords that have 3-prong grounding type plugs and matching 3-conductor receptacles that accept the machine's plug, as shown in Fig. A.

Repair or replace damaged or worn cord immediately.

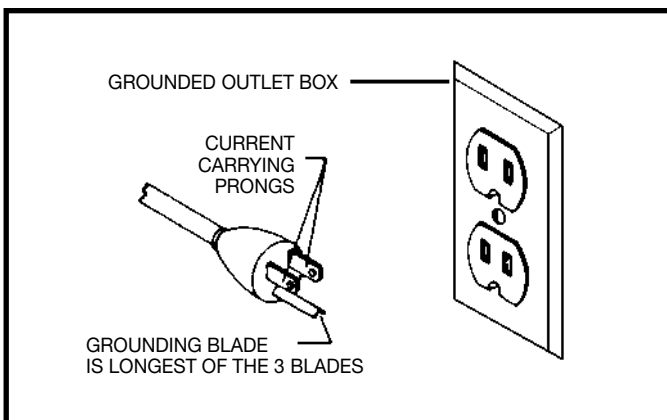

Fig. A

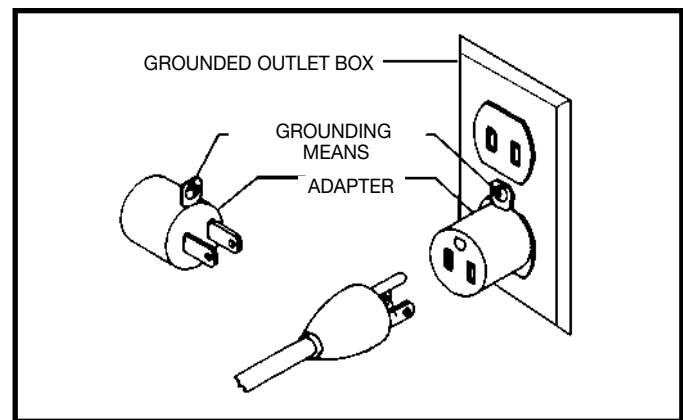

Fig. B

2. Grounded, cord-connected machines intended for use on a supply circuit having a nominal rating less than 150 volts:

If the machine is intended for use on a circuit that has an outlet that looks like the one illustrated in Fig. A, the machine will have a grounding plug that looks like the plug illustrated in Fig. A. A temporary adapter, which looks like the adapter illustrated in Fig. B, may be used to connect this plug to a matching 2-conductor receptacle as shown in Fig. B if a properly grounded outlet is not available. The temporary adapter should be used only until a properly grounded outlet can be installed by a qualified electrician. The green-colored rigid ear, lug, and the like, extending from the adapter must be connected to a permanent ground such as a properly grounded outlet box. Whenever the adapter is used, it must be held in place with a metal screw.

NOTE: In Canada, the use of a temporary adapter is not permitted by the Canadian Electric Code.

⚠ DANGER IN ALL CASES, MAKE CERTAIN THAT THE RECEPTACLE IN QUESTION IS PROPERLY GROUNDED. IF YOU ARE NOT SURE, HAVE A QUALIFIED ELECTRICIAN CHECK THE RECEPTACLE.

EXTENSION CORDS

CAUTION Use proper extension cords. Make sure your extension cord is in good condition and is a 3-wire extension cord which has a 3-prong grounding type plug and matching receptacle which will accept the machine's plug. When using an extension cord, be sure to use one heavy enough to carry the current of the machine. An undersized cord will cause a drop in line voltage, resulting in loss of power and overheating. Fig. D, shows the correct gauge to use depending on the cord length. If in doubt, use the next heavier gauge. The smaller the gauge number, the heavier the cord.

MINIMUM GAUGE EXTENSION CORD			
RECOMMENDED SIZES FOR USE WITH STATIONARY ELECTRIC MACHINES			
Ampere Rating	Volts	Total Length of Cord in Feet	Gauge of Extension Cord
0-6	120	up to 25	18 AWG
	120	25-50	16 AWG
	120	50-100	16 AWG
	120	100-150	14 AWG
6-10	120	up to 25	18 AWG
	120	25-50	16 AWG
	120	50-100	14 AWG
	120	100-150	12 AWG
10-12	120	up to 25	16 AWG
	120	25-50	16 AWG
	120	50-100	14 AWG
	120	100-150	12 AWG
12-16	120	up to 25	14 AWG
	120	25-50	12 AWG
	120	GREATER THAN 50 FEET NOT RECOMMENDED	

Fig. D

FUNCTIONAL DESCRIPTION

FOREWORD

The Delta Model 22-580 is a 13" (330mm) Portable Planer that has a cutting capacity of 13" (330mm) wide, 6½" (165mm) thick and 1/8" (3mm) deep. This machine has a powerful 15 amp 120 volt motor with a two-knife cutterhead.

UNPACKING AND CLEANING

Carefully unpack the machine and all loose items from the shipping container. Peel protective film from the table surface. Figures 1 and 2 illustrate the planer and all loose items supplied with your machine. Refer to the section of this manual entitled "**REPLACING KNIVES**" to remove the cutterhead guard. Remove the protective coating from the cutterhead. This coating may be removed with a soft cloth moistened with kerosene (**do not use acetone, gasoline or lacquer thinner for this purpose.**)

CAUTION Take care when you clean the cutterhead. The knives in the cutterhead are very sharp. After cleaning the cutterhead, replace the cutterhead guard.

NOTICE: The photo on the manual cover illustrates the current production model. All other illustrations contained in the manual are representative only and may not depict the actual color, labeling, or accessories, and are intended to illustrate technique only.

CARTON CONTENTS

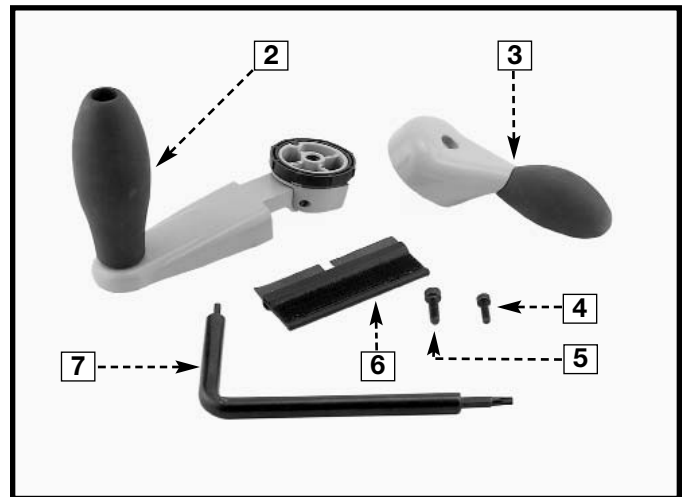

1. 13" Two-Speed Finishing Planer
2. Cutterhead Adjusting Handle
3. Cutterhead Lock Handle

4. M5-16mm Hex Socket Head Screw
5. M6-20 mm Hex Socket Head Screw
6. Knife Transfer Tool
7. Cutterhead Wrench and Handle Combination

ASSEMBLY

⚠ WARNING For your own safety, do not connect the machine to the power source until the machine is completely assembled and you read and understand the entire instruction manual.

ASSEMBLY TOOLS REQUIRED

Cutterhead Wrench (Supplied)

ASSEMBLY TIME ESTIMATE

Approximately 1/2 hour

OPTIONAL 4" REVERSIBLE DUST COLLECTION ATTACHMENT

To attach an optional dust collection attachment (A) Fig. 1 to mount a dust collection system to the planer.

1. Remove the two screws (A) Fig. 2 that secure the cutterhead guard.
2. Place the dust connector in the slots provided and replace the cutterhead guard screws(A) Fig. 2.

NOTE: You can mount the attachment on either side of the machine.

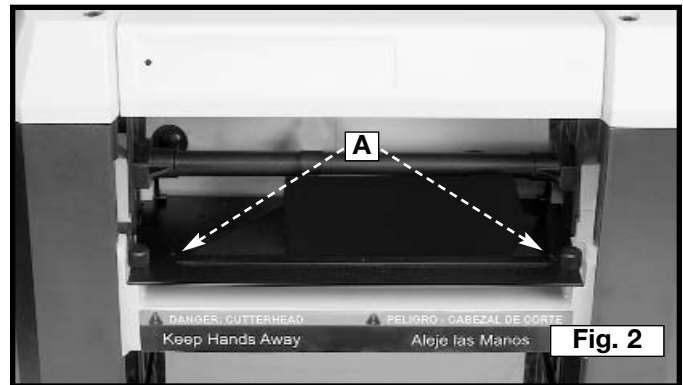
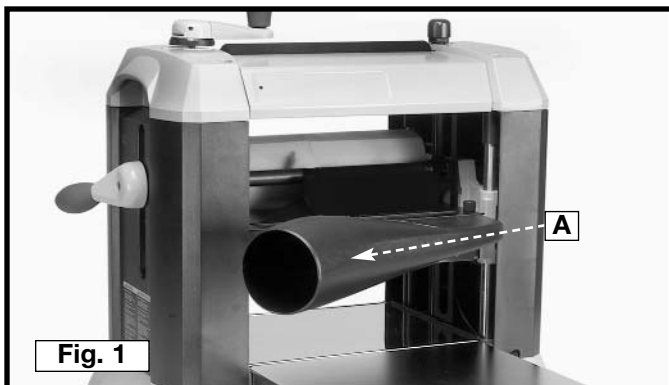

LOWERING THE EXTENSION TABLES

The infeed and outfeed table extensions (A) Fig. 3 are shipped in the "UP" position on the machine. Lower both table extensions (A) to the "DOWN" position (Fig. 3). To check and adjust the top surface of the table extensions (A) level with the planer table, refer to the section of this manual entitled "LEVELING TABLE EXTENSIONS."

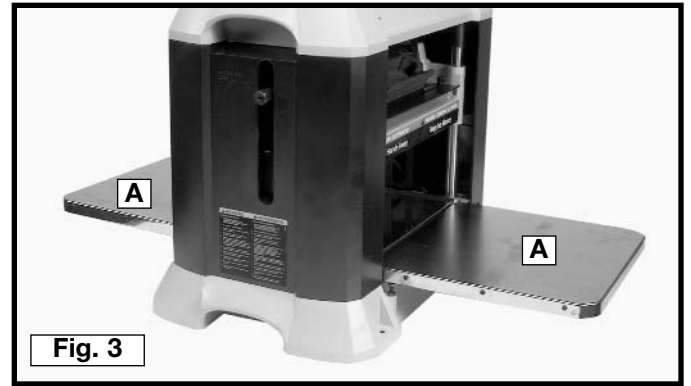

CUTTERHEAD LOCK HANDLE

Use the supplied wrench to attach the cutterhead lock handle (A) Figs. 3 & 4, to the shaft (B) with the M6-20mm hex socket-head screw (C) Fig. 4.

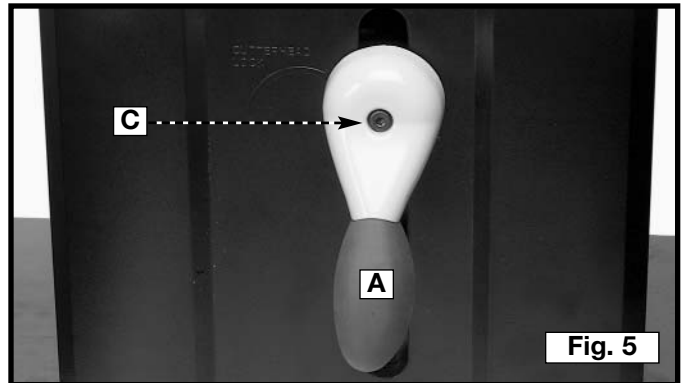
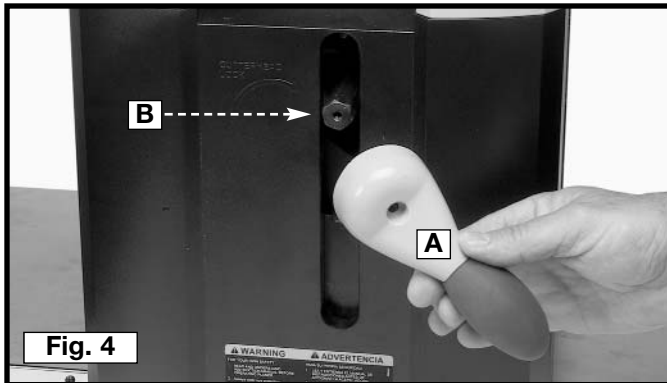

CUTTERHEAD ADJUSTMENT HANDLE

1. Attach the cutterhead adjustment handle (A) Fig. 6 to the shaft (B), making certain that the flat on the shaft is engaged with the flat in the handle.
2. Fasten the cutterhead adjustment handle (A) Fig. 7 to the shaft using the M5 x 16mm hex socket-head screw (C) with the hex end of the supplied cutterhead wrench.
3. Rotate handle (A) to the operating position as shown in Fig. 8.

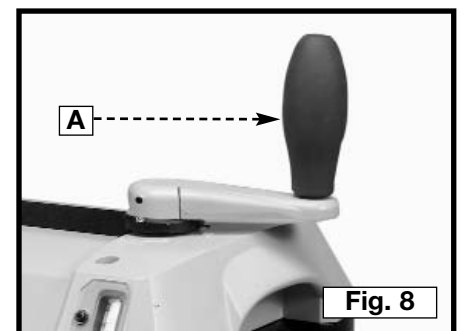
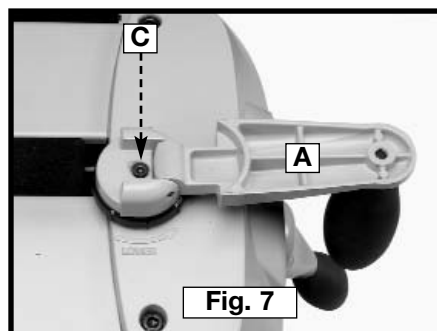
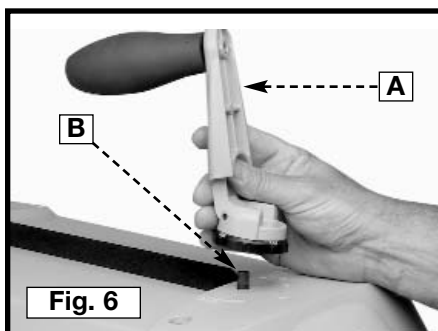

FASTENING PLANER TO SUPPORTING SURFACE

⚠ CAUTION During operation, if there is any tendency for the planer to tip over, slide or “walk” across the supporting surface, the planer must be secured to the supporting surface. Four holes (two of which are at (A) Fig. 9) are provided for this purpose.

⚠ CAUTION Operate the planer on a flat, level surface.

If you attach the planer to the one of the accessory stands (models 50-326 or 50-322), align the four holes in the base of the machine, two of which are shown at (A) Fig. 9, with the four holes in the top of the stand. Place the carriage head flange bolt through the holes in the planer and the stand. Thread the flange nut on the carriage head flange bolt. Tighten it securely.

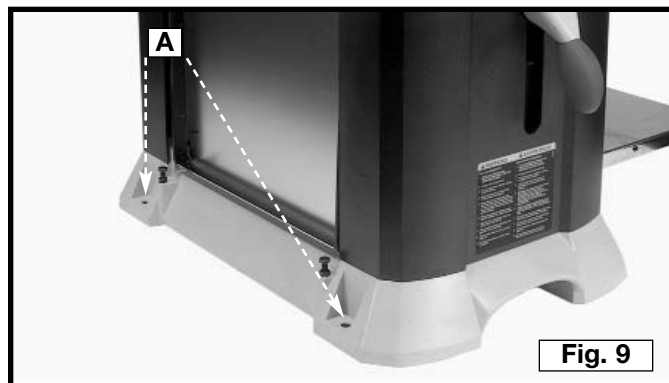

OPERATION

OPERATIONAL CONTROLS AND ADJUSTMENTS

STARTING AND STOPPING THE PLANER

The on/off switch Fig. 10 is located on the front of the planer motor. To turn the machine “ON”, move the switch (A) up to the “ON” position. To turn the machine “OFF”, push down on the switch shield (B) Fig. 10.

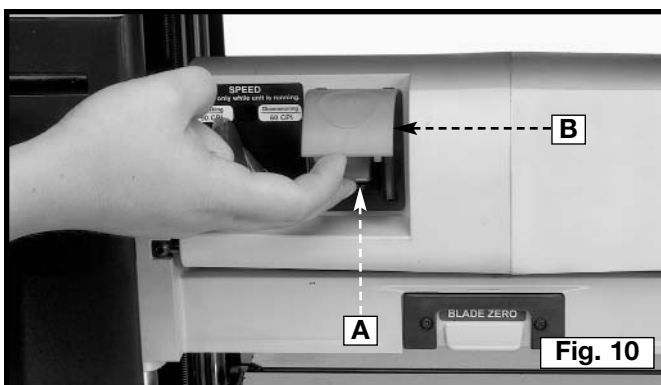

LOCKING THE SWITCH IN THE “OFF” POSITION

IMPORTANT: When the machine is not in use, the switch should be locked in the “OFF” position to prevent unauthorized use. Raise the infeed table to the upright position. Place a padlock with a 3/16" diameter shackle through the hole in the left side of the planer and through the infeed table (Fig. 11). Lock the padlock.



ADJUSTING THE HEAD ASSEMBLY

The head assembly (A) Fig. 12 contains the cutterhead, feed rollers, chip deflector and motor. Raising and lowering the head assembly (A) controls the depth of cut. To adjust the head assembly, rotate the cutterhead lock handle (B) counter-clockwise to unlock the cutterhead. Turn the cutterhead adjusting handle (C) clockwise to raise or counter-clockwise to lower the cutterhead (A). One revolution of handle (C) will move the cutterhead up or down 1/16".

CUTTERHEAD LOCK

The cutterhead lock helps to eliminate snipe in the board that is being planed. Snipe can also be eliminated by butting boards end to end and feeding them through the planer. Long boards should always be supported, when feeding them through the planer to help eliminate snipe.

SCALE AND POINTER

A dual English/Metric scale (D) Fig. 13 and pointer (E) is located on the front of the machine. This scale indicates the thickness of the finished workpiece. To adjust the pointer (E), plane a piece of wood through the machine. Measure the thickness of the workpiece. If an adjustment is necessary, loosen the screw (F) and adjust the pointer (E). Tighten the screw (F).

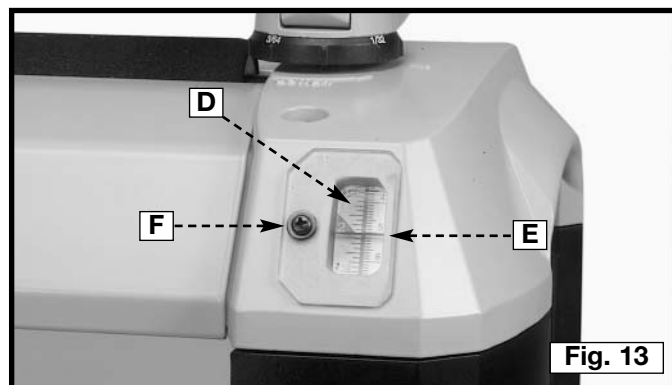
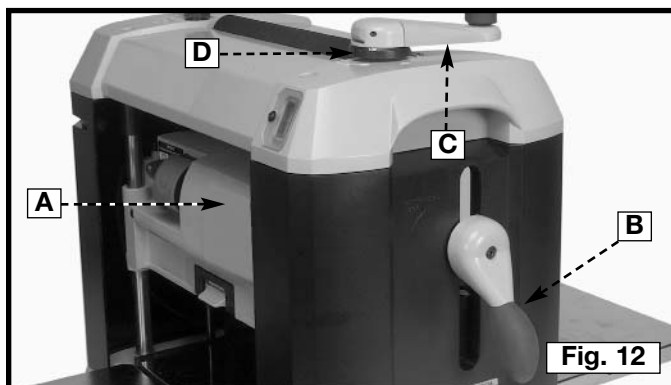

SPEED CONTROL

CAUTION Change speeds only while the motor is running. Do not change speeds while planing.

CAUTION Make sure that the speed control is fully engaged before feeding work material.

1. The 22-580 is a two-speed planer. The speed control knob (A) is shown in Fig. 14.
2. Use the "Dimensioning" speed (B) Fig. 14 with 60 cuts per inch to size the board.
3. Use the "Finishing" speed (C) Fig. 14 with 90 cuts per inch to finish your workpiece.

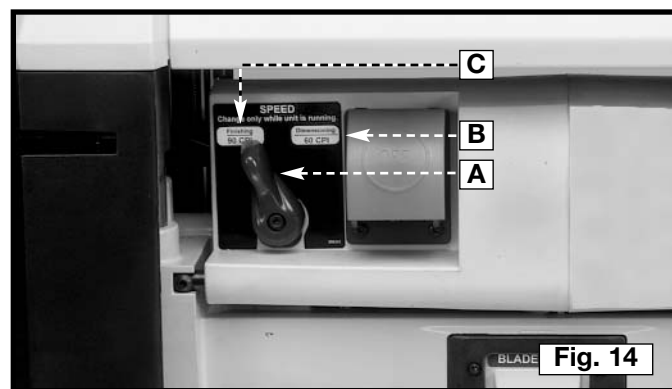

FULL RANGE DEPTH STOP

1. You can use the depth stop (A) Fig. 15 to set the cutterhead to a pre-determined thickness. The stop can be set at any depth from 1/8" to 6-1/2" for repetitive planing.
2. To set the depth stop, lower the cutterhead to the desired depth.
3. Rotate the depth stop knob (A) Fig. 15 clockwise, while applying light downward pressure, until it stops.

NOTE: If you rotate the depth stop knob past the stopping point, the cutterhead adjusting handle will start to move.

4. Push down on the depth stop knob and turn the knob approximately 1/4 turn clockwise until the depth stop engages.
5. Raise the cutterhead to allow for the workpiece. As it is planed down, the cutterhead will stop at the height at which the depth stop was engaged.
6. To disengage the depth stop, raise the cutterhead 1/2 turn, and turn the depth stop knob counter-clockwise.

CAUTION Disengage the depth stop when it is not being used.

ADJUSTABLE INDEXING RING

The cutterhead adjusting handle has an adjustment ring (A) Fig. 16. To use the adjustment ring to make fine adjustments:

1. Measure the thickness of a planed board.
2. Set the zero position of the ring to align with the arrow.
3. Rotate the handle to the desired depth of cut, as indicated on the ring. Each indicator on the ring is equivalent to 1/128" for making minute cuts.
4. Plane the workpiece.

BLADE ZERO INDICATOR

The blade zero indicator marks exactly where the cutterhead and the workpiece make contact, and allows you to measure your cuts precisely. To set the indicator:

1. Push down on the zero indicator (A) Fig. 17 to engage.
2. Place the end of the board (B) Fig. 18 underneath the blade zero indicator(A).
3. Lower the cutterhead until the workpiece contacts the bottom of the zero indicator (A) Fig. 18
4. When the zero indicator has been contacted, it will disengage.

NOTE: Lower the cutterhead slowly when using the zero indicator so that the cutterhead does not go beyond the disengagement spot.

WARNING Do not plane with the blade zero indicator engaged.

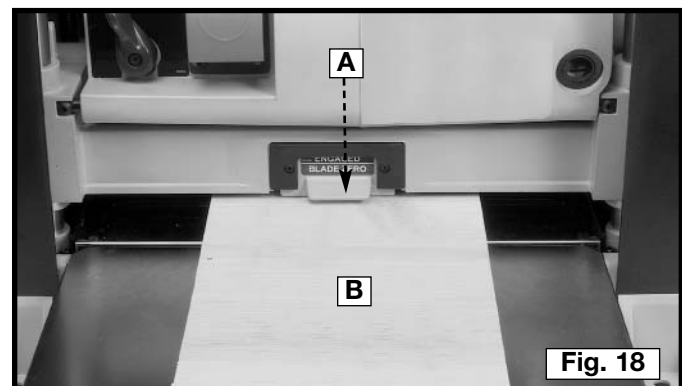
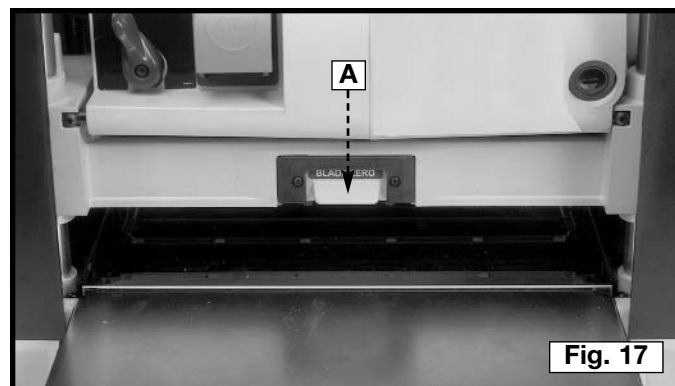
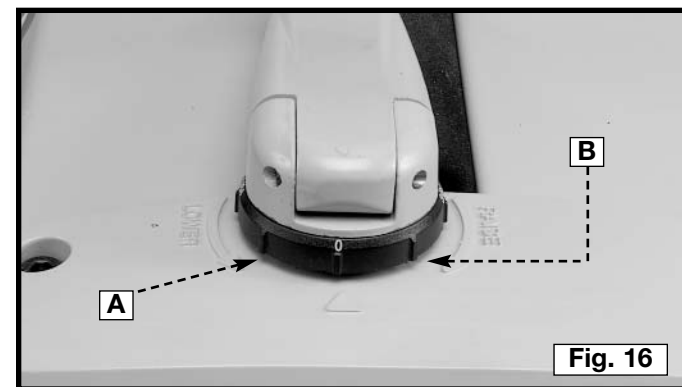
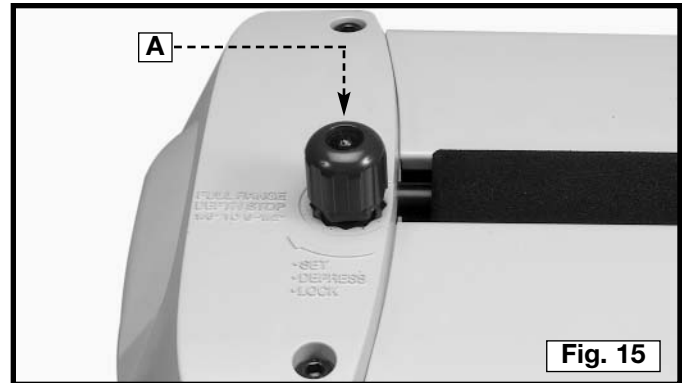

LEVELING TABLE EXTENSIONS

For optimum performance, level the table extensions, one of which is shown at (A) Fig. 19, with the planer table. To check and adjust:

⚠ WARNING DISCONNECT MACHINE FROM POWER SOURCE!

1. Place a straight edge (B) Fig. 19 on the planer table with one end of the straight edge extending out over the infeed table extension (A). Check to see if the table extension is level with the planer table on both sides of table extension.
2. If an adjustment is necessary, loosen the locknut (D) and adjust the stop screw (E) on each side of the table (A). When they are level, tighten the locknut.

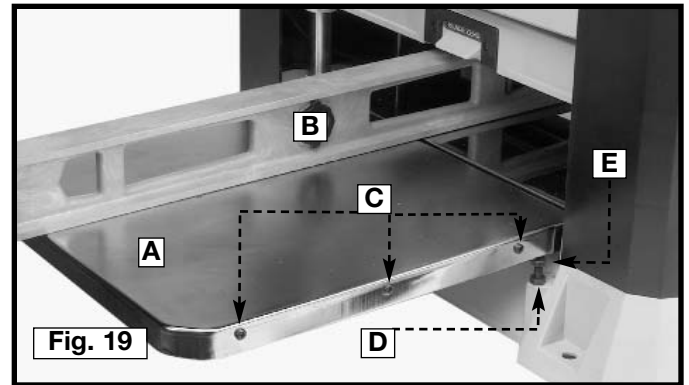

NOTE: If necessary, loosen the three screws (C), adjust the table extension, and tighten the screws (C).

3. Adjust the opposite side of the table extension (A).
4. Check and adjust other table extension.

ADJUSTING THE HEIGHT OF THE OUTFEED ROLLER

⚠ WARNING DISCONNECT MACHINE FROM POWER SOURCE!

1. To check and adjust the outfeed roller, make a gauge block of hardwood. Follow the dimensions in Fig. 20.
2. Check the knives to be certain that they were inserted correctly (See “REPLACING KNIVES.”)
3. Position the gauge block (A) Fig. 21 on the table underneath the cutterhead. Insert a 0.020" feeler gauge underneath the gauge block. Lower the head assembly and rotate the cutterhead (follow **STEP 5** under “REPLACING KNIVES,”) until one of the knives (B) touches the top of the gauge block. Tighten the cutterhead lock handle.
4. Remove the feeler gauge and move the gauge block (A) Fig. 22 under one end of the outfeed roller (C). The bottom of the outfeed roller should touch the top of the gauge block.
5. To adjust the outfeed roller, loosen the locknut (D) Fig. 22 and use a hex wrench to turn the adjusting screw (E) until outfeed roller touches the gauge block (A). Tighten the locknut.
6. Repeat this adjustment on opposite side of the outfeed roller.

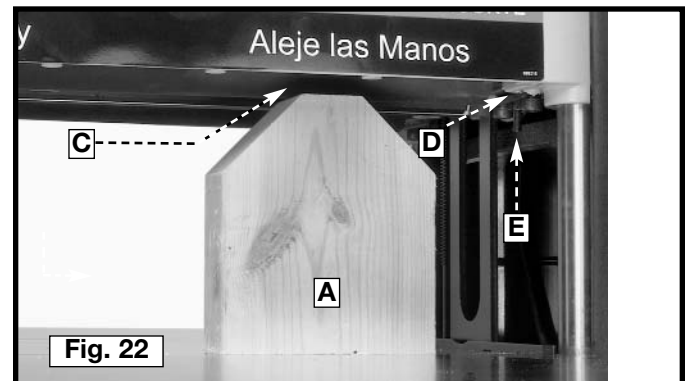
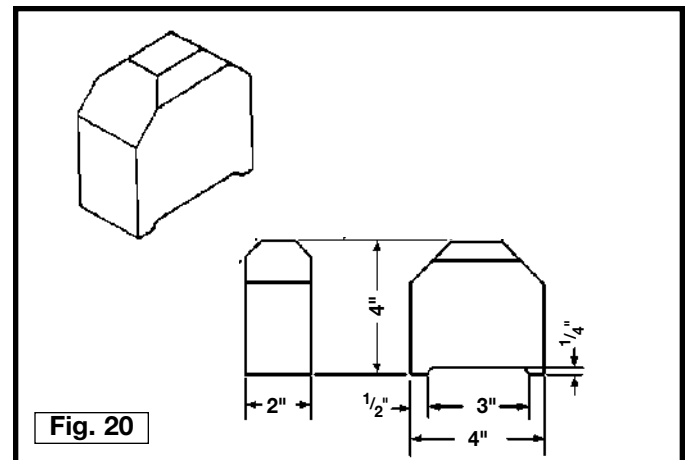

MACHINE USE

RECOMMENDED DEPTH OF CUT

NOTE: One revolution of the cutterhead adjusting handle will move the cutterhead up or down 1/16".

You can make an 1/8" depth of cut in soft woods up to 6" wide and in hard woods up to 4" wide. (See Fig. 23).

For 10", 12", and 13" wide soft wood, use a maximum depth-of-cut of 1/16". For 10", 12", and 13" wide hard wood, use a maximum depth-of-cut of 3/64" (Fig. 23).

IMPORTANT: A shallow depth-of-cut will produce a better finish.

CAUTION Continuous operation at more than 3/64" can cause motor damage.

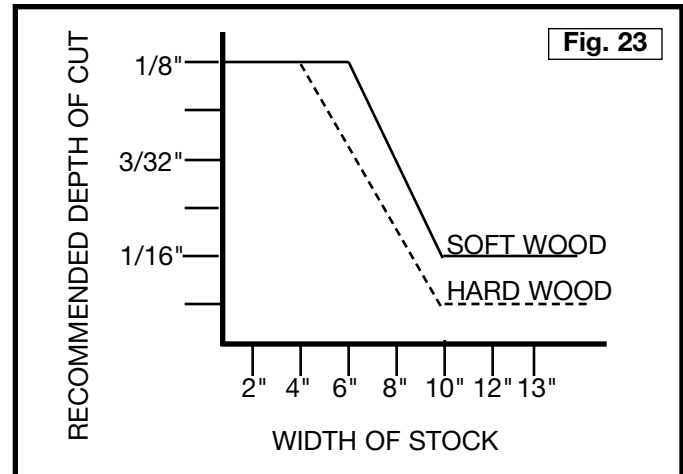

OPERATING HINTS

When using your machine, follow these few simple steps to achieve the best results.

1. True Up One Face – Feed one face of the board through a jointer. Make thin cuts with each pass until the entire surface is flat.
2. Plane to Thickness – Place the surfaced side (**STEP 1**) face down and feed the board through a planer until the opposite side is flat. Plane both sides of the board until you achieve your desired thickness. Make thin cuts, alternating sides with each pass. If, during the planing operation, you notice the board twisting, warping or bowing, start again with **STEP 1**.
3. Support both ends of the long workpieces.
4. For best results, engage the cutterhead lock before planing. Plane with the grain only. Keep the planer table clean. Occasionally, wax the table surface to reduce friction during the planing operation.
5. Cross-cut your lumber to the final length.

CAUTION The knives on the planer will not wear evenly if the wood is fed through the same spot on the table every time. Feed the wood through the planer at different spots on the table when possible to help eliminate uneven wear of the knives.

KNIFE TRANSFER TOOL STORAGE

You can store your supplied knife transfer tool (A) Fig. 24 underneath the outfeed table extension (B) on the Velcro strip.

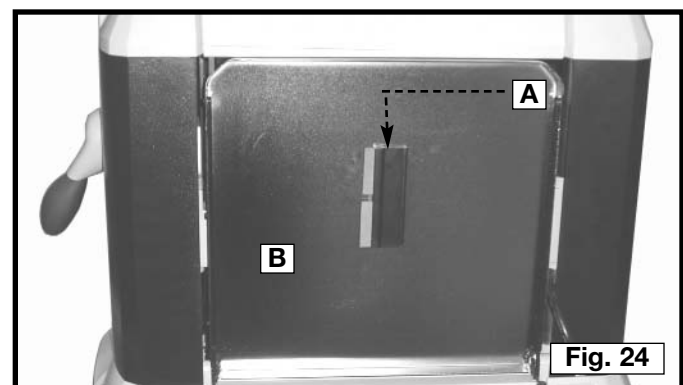

WRENCH STORAGE

You can store your supplied wrench (A) Fig. 25 in the wrench storage hole (B), located on the left rear side of the machine.

CARRYING HANDLES

Carrying handles (B) Fig. 26 are provided on both sides of the planer at the base and the top.

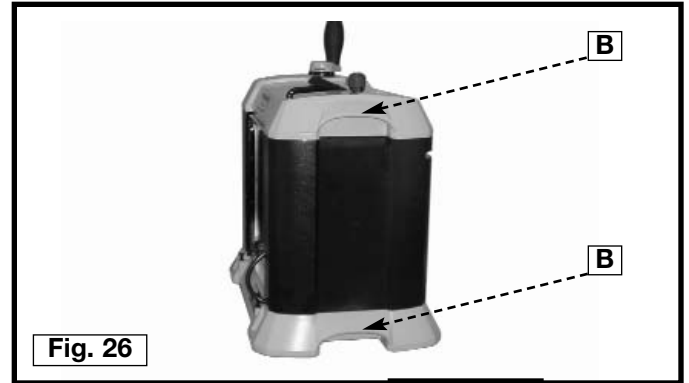
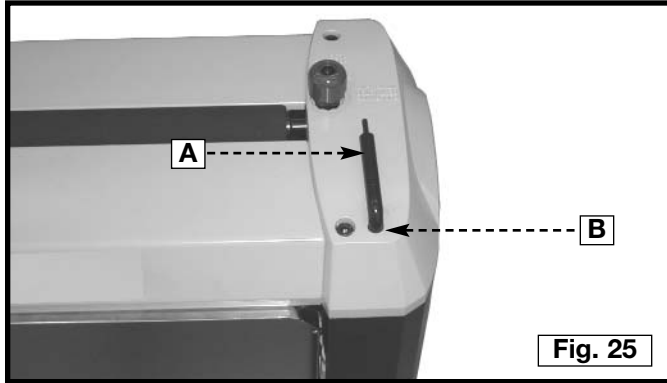

STOCK TRANSFER BAR

You can use the stock transfer bar (A) Fig. 27 for transferring stock (especially long workpieces) from the outfeed end to the infeed end of the machine for additional cuts.

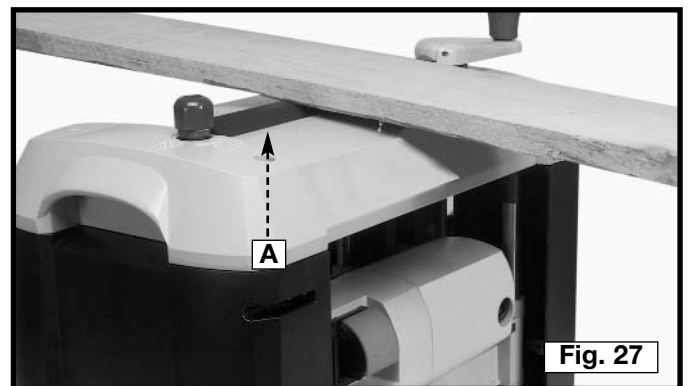

TROUBLESHOOTING

For assistance with your machine, visit our website at www.deltamachinery.com for a list of service centers or call the DELTA Machinery help line at 1-800-223-7278 (In Canada call 1-800-463-3582).

MAINTENANCE

REPLACING KNIVES

The knives supplied with your planer are double edged and reversible so that you can turn the knives end-for-end when one edge becomes dull or chipped. To change the knives:

⚠ WARNING DISCONNECT MACHINE FROM POWER SOURCE!

1. Remove the two top covers (C) Fig. 28.
2. Raise the head assembly (B) to 4" on the "Scale and Pointer".
3. Remove the two screws (A) Fig. 28. Pull the cutterhead guard (B) straight out.

⚠ WARNING The knives are sharp. Be careful when removing, handling, or installing knives.

4. Pull the guard down (G) Fig. 29 to gain access to the hex hole in the end of the cutterhead.
5. Insert the supplied wrench into the hex hole (A) Fig. 29. Rotate the cutterhead until the cutterhead lock engages.

6. Use the wrench (E) Fig. 30 to loosen the seven screws (F) enough to allow the locking bar (D) to separate from the knife.

7. Place the magnetized knife transfer tool (G) Fig. 31 under the center of the knife. Lift the knife transfer tool until the knife (H) separates from the pins. Remove the knife.

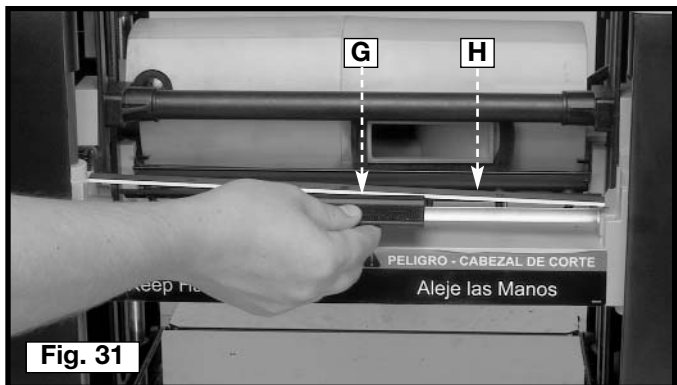
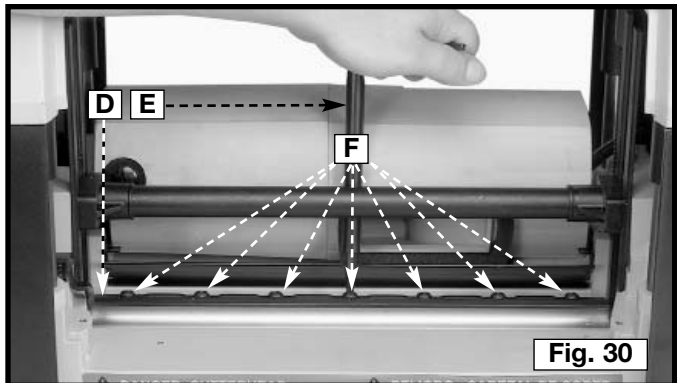
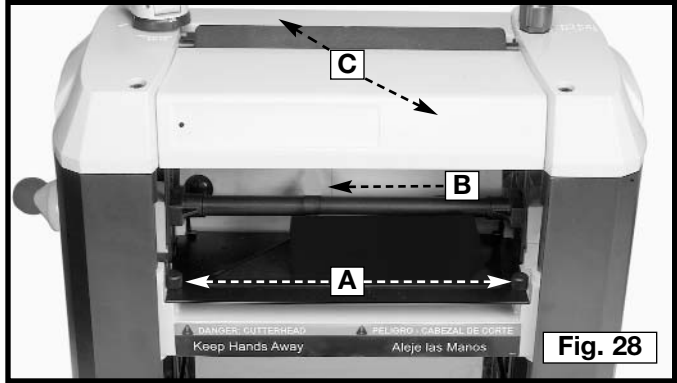

8. Reverse the knife (H) Fig. 32 or install a new knife. Position the magnetized knife transfer tool (G) on top of knife. Place the knife in the cutterhead underneath the locking bar (D) with the bevel edge up. Ensure that the pins in the cutterhead and locking bar engage with the holes in the knife.
9. Remove the magnetized knife transfer tool and tighten the seven screws loosened in **STEP 7**.
10. To replace the other knife, repeat **STEPS 5 THROUGH 10**.

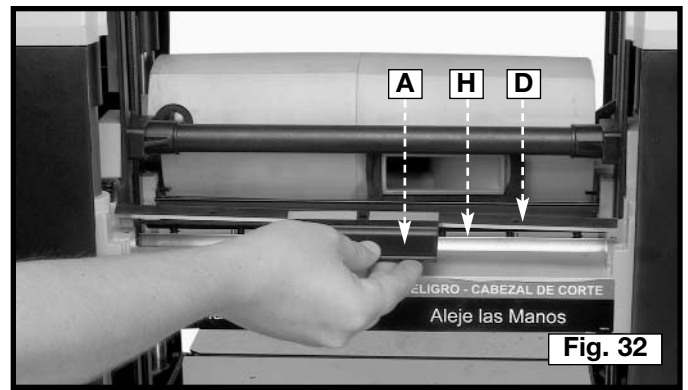

Fig. 32

11. After both knives are installed, depress the cutterhead lock (D) Fig. 33. Place the cutterhead guard in position and over the cutterhead lock. Slide the guard in as far as possible. Replace the two screws (A) Fig. 33 that were removed in **STEP 3**.

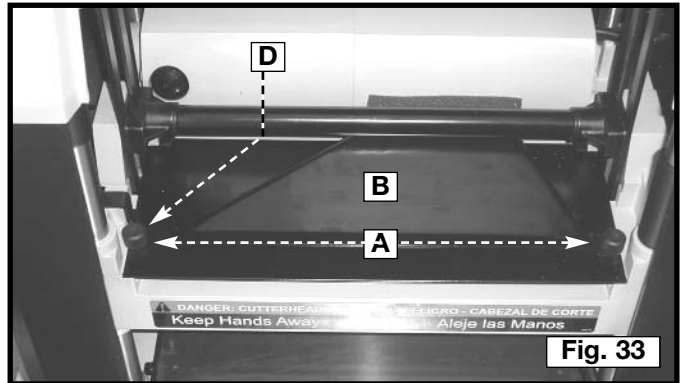

Fig. 33

BRUSH INSPECTION AND REPLACEMENT

⚠ WARNING DISCONNECT TOOL FROM POWER SOURCE!

Brush life varies. It depends on the load on the motor. Check the brushes after the first 50 hours of use for a new machine or after a new set of brushes has been installed. After the first check, examine them after about every 10 hours of use until replacement is necessary.

The brush holders, one of which is shown at (A) Fig. 34, are located on the motor housing opposite each other. One of the removed brushes is illustrated in Fig. 35. When the carbon (B) on either brush is worn to 3/16" in length or if either spring (C) or shunt wire is burned or damaged, replace both brushes. If the brushes are found serviceable after removing, reinstall them.

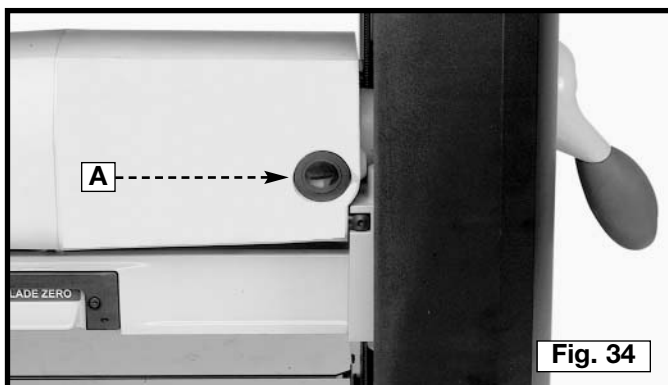

Fig. 34

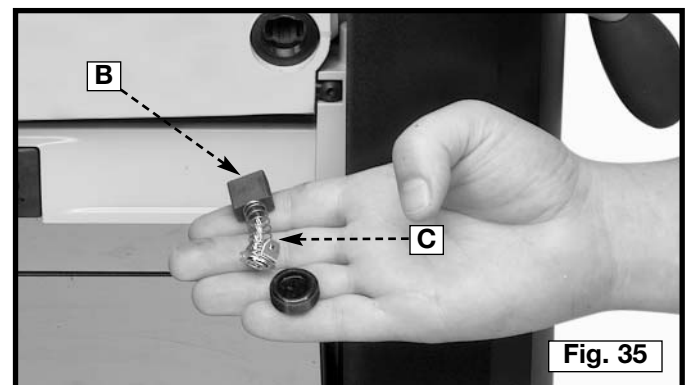

Fig. 35

LUBRICATION

To periodically lubricate the gears in the gear box, the feed roller bushings, and the spindles and columns:

⚠ WARNING DISCONNECT TOOL FROM POWER SOURCE!

1. Remove the two top covers (A) Fig. 36.
2. Remove the screw (B) Fig. 38. Remove the depth stop assembly.
3. Remove the two 6mm screws (C) Fig. 36.
4. Lift the top left machine cover (D), and pull out the side cover (E) Fig. 36.
5. Remove the two screws (F) Fig. 37 and remove the gear housing cover (D) Fig. 37.
6. Place extreme pressure lithium grease on the gear teeth (H) Fig. 38. Replace the gear housing cover.
7. Clean and oil the columns (J) Fig. 38 and the spindles (K) with a light-weight machine oil.
8. Reassemble the planer.
9. Place the planer on its back and put oil on the feed roller bushings (L) Fig. 41, two of which are shown, at each end of the feed rollers.

LUBRICATING THE BEARING BLOCKS

Position the machine on its end (Fig. 39). Place 2 drops of 30 weight oil on the shaft (A) Fig. 40 at the bearing block (B). Allow the oil to flow into the bearing block.

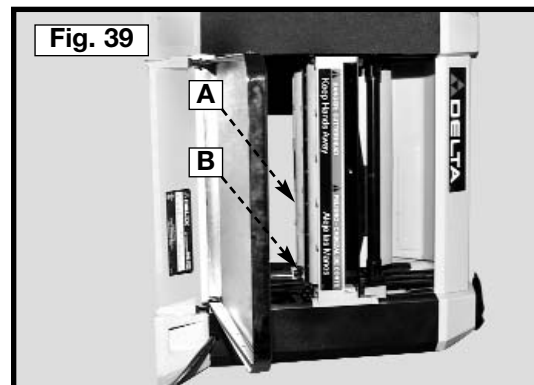
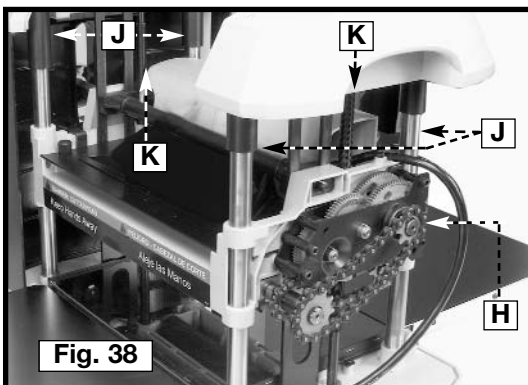
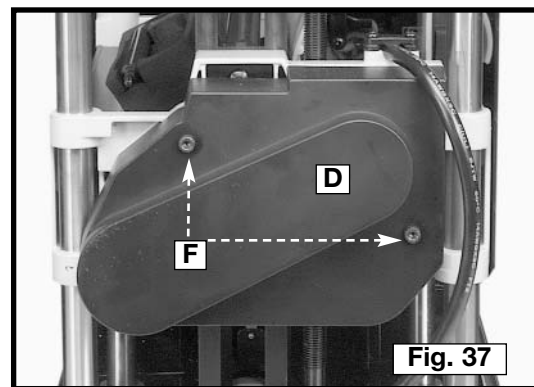
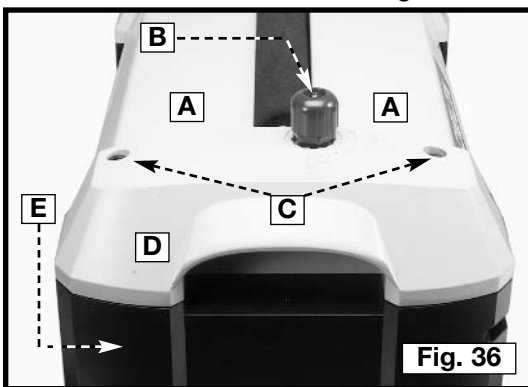

CLEANING INFED AND OUTFEED ROLLERS

You will need to clean the infed and outfeed rollers (M) Fig. 40 periodically. Use soap, water, and a scotch-brite pad.

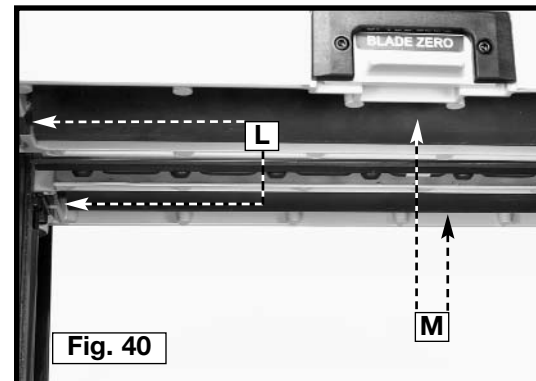

KEEP MACHINE CLEAN

Periodically blow out all air passages with dry compressed air. All plastic parts should be cleaned with a soft damp cloth. NEVER use solvents to clean plastic parts. They could possibly dissolve or otherwise damage the material.

▲WARNING Wear ANSI Z87.1 safety glasses while using compressed air.

FAILURE TO START

Should your machine fail to start, check to make sure the prongs on the cord plug are making good contact in the outlet. Also, check for blown fuses or open circuit breakers in the line.

LUBRICATION

Apply household floor paste wax to the machine table and extension table or other work surface weekly.

PROTECTING CAST IRON FROM RUST

To clean and protect cast iron tables from rust, you will need the following materials: 1 pushblock from a jointer, 1 sheet of medium Scotch-Brite™ Blending Hand Pad, 1 can of WD-40®, 1 can of degreaser, 1 can of TopCote® Aerosol. Apply the WD-40 and polish the table surface with the Scotch-Brite pad using the pushblock as a holddown. Degrease the table, then apply the TopCote® accordingly.

SERVICE



PARTS, SERVICE OR WARRANTY ASSISTANCE

All Delta Machines and accessories are manufactured to high quality standards and are serviced by a network of Porter-Cable • Delta Factory Service Centers and Delta Authorized Service Stations. To obtain additional information regarding your Delta quality product or to obtain parts, service, warranty assistance, or the location of the nearest service outlet, please call 1-800-223-7278 (In Canada call 1-800-463-3582).

ACCESSORIES

A complete line of accessories is available from your Delta Supplier, Porter-Cable • Delta Factory Service Centers, and Delta Authorized Service Stations. Please visit our Web Site www.deltamachinery.com for a catalog or for the name of your nearest supplier.

▲WARNING Since accessories other than those offered by Delta have not been tested with this product, use of such accessories could be hazardous. For safest operation, only Delta recommended accessories should be used with this product.



22-580
13" TWO-SPEED
FINISHING PLANER

P-12

PARTS LIST NO. 901531

Date: 8/28/03

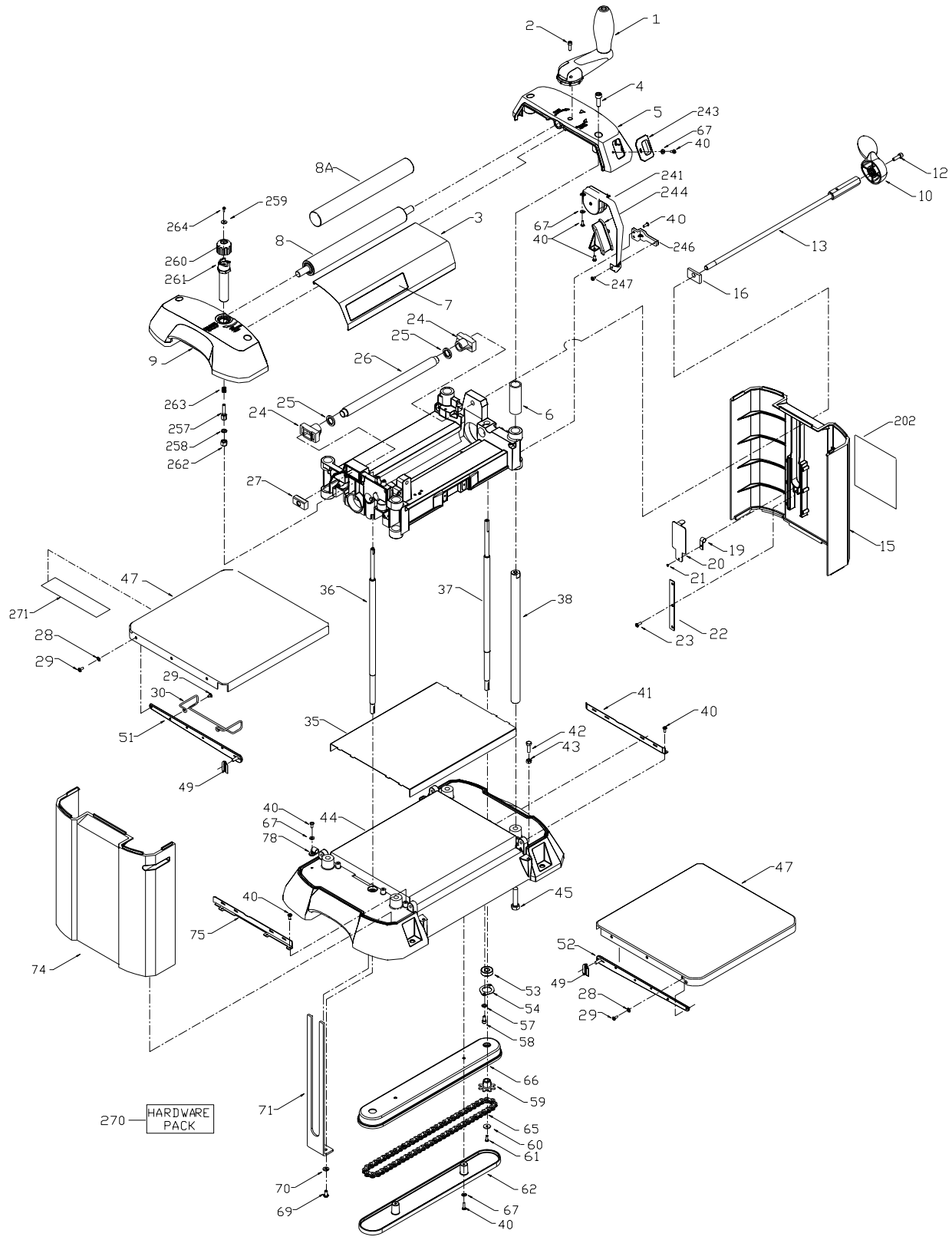

REPLACEMENT PARTS

Ref.			Ref.		
<u>No.</u>	<u>Part No.</u>	<u>Description</u>	<u>No.</u>	<u>Part No.</u>	<u>Description</u>
1	903452	HANDLE ASSY	51	899301	RIGHT TABLE SUPPORT
2	1246098	M5 X .8 X 16 SCREW	52	899412	LEFT TABLE SUPPORT
3	899368	TOP COVER	53	1341072	BEARING
4	1246053	M8 X 1.25 X 25 SCREW	54	1342197	BEARING RETAINER
5	899278	RIGHT COLUMN SUPPORT	57	1343538	5.1 MM LOCK WASHER
6	900309	STOP, NOTE A	58	1246051	M5 X 0.8 X 12 SCREW
7	899322	NAMEPLATE	59	899302	SPROCKET
8	901359	HANDLE ASSY, INCL...: REF. 8A	60	1342225	SPACER
8A	899279	COVER	61	1349832	M 04 X 0.7 SCREW
9	899281	LEFT COLUMN SUPPORT	62	899303	GUARD
10	899283	HANDLE	65	899304	CHAIN
12	1342220	M6 X 20MM SCREW	66	899305	CHAIN GUARD
13	899287	LOCK ROD ASSY	67	1343545	4.MM FLAT WASHER
15	899289	RIGHT SIDE COVER	69	1345859	M6 X 1.00 X 12 SCREW
16	1342222	LOCKING PLATE	70	1243520	6.1MM LOCK WASHER
19	1342196	SPRING	71	899306	PLATE
20	1342169	GUARD	74	899307	LEFT SIDE COVER
21	1349866	RIVET	75	899308	LEFT GUIDE RAIL
22	900124	GUIDE PLATE	78	1330682	CLAMP
23	900310	M4 X 10MM SCREW	202	899360	WARNING LABEL
24	1342160	HEAD LOCK SHOE	241	903450	TAPE MEASURE ASSY
25	1342162	SPACER	243	899375	FRONT CURSOR
26	899290	TUBE	244	899376	CURSOR BACK
27	903535	NUT	246	899377	TAPE BRACKET
28	1310210	M8 WASHER	247	900478	M4 X 6MM SCREW
29	1246177	M4 X 0.7 X 6 SCREW	257	901530	SHAFT
30	899291	CORD WRAP, EMO	258	901529	NYLON SPACER
35	899292	WEAR PLATE	259	899285	M3 WASHER
36	899293	ELEVATING SCREW-L.H.	260	901156	KNOB
37	899294	ELEVATING SCREW-R.H.	261	901153	SLEEVE ASSY
38	899295	COLUMN	262	901154	NUT
40	1243501	M4 X .7 X 10 SCREW	263	901155	SPRING
41	899297	RIGHT GUIDE RAIL	264	901144	M3 X 8MM SCREW
42	1343101	M6 X 25MM SCREW	270	903556	HARDWARE PACK
43	1243456	M06 X 1.00 HEX NUT	271	n 1342217	KNIFE TOOL HOLDER
44	899299	BASE			
45	1330158	M10 X 1.5 X 45 SCREW			
47	899300	INFEED/OUTFEED TABLE			
49	899383	SPRING			

REPLACEMENT PARTS

Ref.			Ref.		
<u>No.</u>	<u>Part No.</u>	<u>Description</u>	<u>No.</u>	<u>Part No.</u>	<u>Description</u>
14	901365	LABEL	140	900141	LOCK
39	899296	WRENCH, SEE NOTE B	141	1342168	SPACER
40	1243501	M4 X .7 X 10 SCREW	142	1246001	M5 X 12MM SCREW
67	1343545	WASHER	143	899320	SPINDLE NUT
69	1345859	M6 X 1.00 X 12 SCREW	145	1342189	MOUNTING PLATE
80	903447	GEARBOX ASSY	150	1320101	WASHER
88	899332	SPRING	151	899321	PIVOT ROD
89	899333	SLEEVE	152	1346165	M5 X 0.8 X 16 SCREW
90	899334	WASHER	154	1343903	GEAR
91	903553	M3 X 0.5 X 8MM SCREW	170	899349	M5 X 45MM SCREW
92	899336	WASHER	171	1343881	SPROCKET
93	899337	RETAINING RING	172	1246196	RETAINING RING
94	899338	GEAR	173	899351	CHAIN
95	1313194	WASHER	174	899350	M5 X 50MM SCREW
96	899340	SHIFTER SHAFT	175	899353	GUARD
97	899341	HANDLE	176	899354	SEAL
98	1243482	M4 X 15 SCREW	181	899355	SPROCKET
100	899372	BALL	182	903475	SPACER
101	899374	M8 X 1 X 10MM SCREW	183	1343882	CHAIN
103	901158	BELT GUARD	185	899356	OUTFEED ROLLER
104	22-563	DRIVE BELT	186	1243569	HEX NUT
105	1343849	HEX NUT	187	1349858	M4 X 15MM SCREW
106	899310	DRIVE PULLEY	188	1349831	SPRING
107	1342455	M5 X .8 X 10 SCREW	189	1343875	BEARING BLOCK
108	1342159	BEARING CUP	190	1342157	MOUNTING PLATE
109	902954	M3 X 0.5 X 8MM SCREW	191	1346203	M5 X 0.8 X 10 SCREW
110	904-03-030-1788	WASHER	192	899357	INFEEED ROLLER
111	1086894	BEARING	201	1345695	CORD CLAMP
112	1342219	BEARING RETAINER	233	1344330	WASHER
113	903468	KEY	234	1346163	M8 X 1.25 X 16 SCREW
114	1342204	SPRING	252	899385	PLATE
115	899311	SCREW (TORQUE TO 80 - 90 IN. LB.)	253	899386	M3 X 0.5 X 6MM BOLT
116	899312	KNIFE LOCKING BAR	254	899387	FACE
117	900528	KNIFE REMOVAL TOOL, EMO	255	899388	SPRING
n	1342213	KNIFE REMOVAL TOOL, CMO	268	901152	SPACER
118	22-549	KNIFE	269	1348888	M4 X 6MM SCREW
119	1342145	PIN			
120	903445	CUTTERHEAD ASSY. , INCL.: REF. 119			
130	1342214	KNOB			
131	899315	WARNING LABEL			
132	899381	MANIFOLD ASSY			
133	899379	TOOL HOLDER, EMO			
134	900125	CHIP DEFLECTOR			
137	1342205	SPRING			
138	899319	HEAD			
139	1349859	M4 X 4MM SCREW			

NOTE B. THIS TOOL WAS STORED IN A SEPARATE TOOL HOLDER REF. 133 ON EARLY MODELS, THIS TOOL IS STORED IN A HOLE LOCATED IN THE LEFT COLUMN SUPPORT, REF. 9 ON CURRENT MODELS

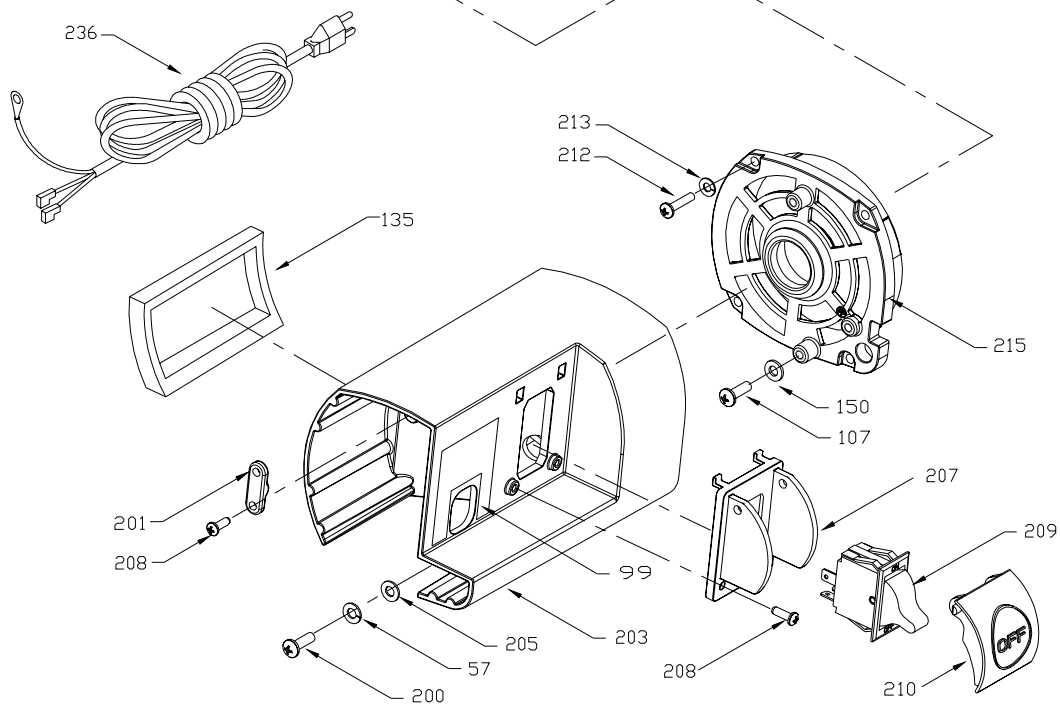
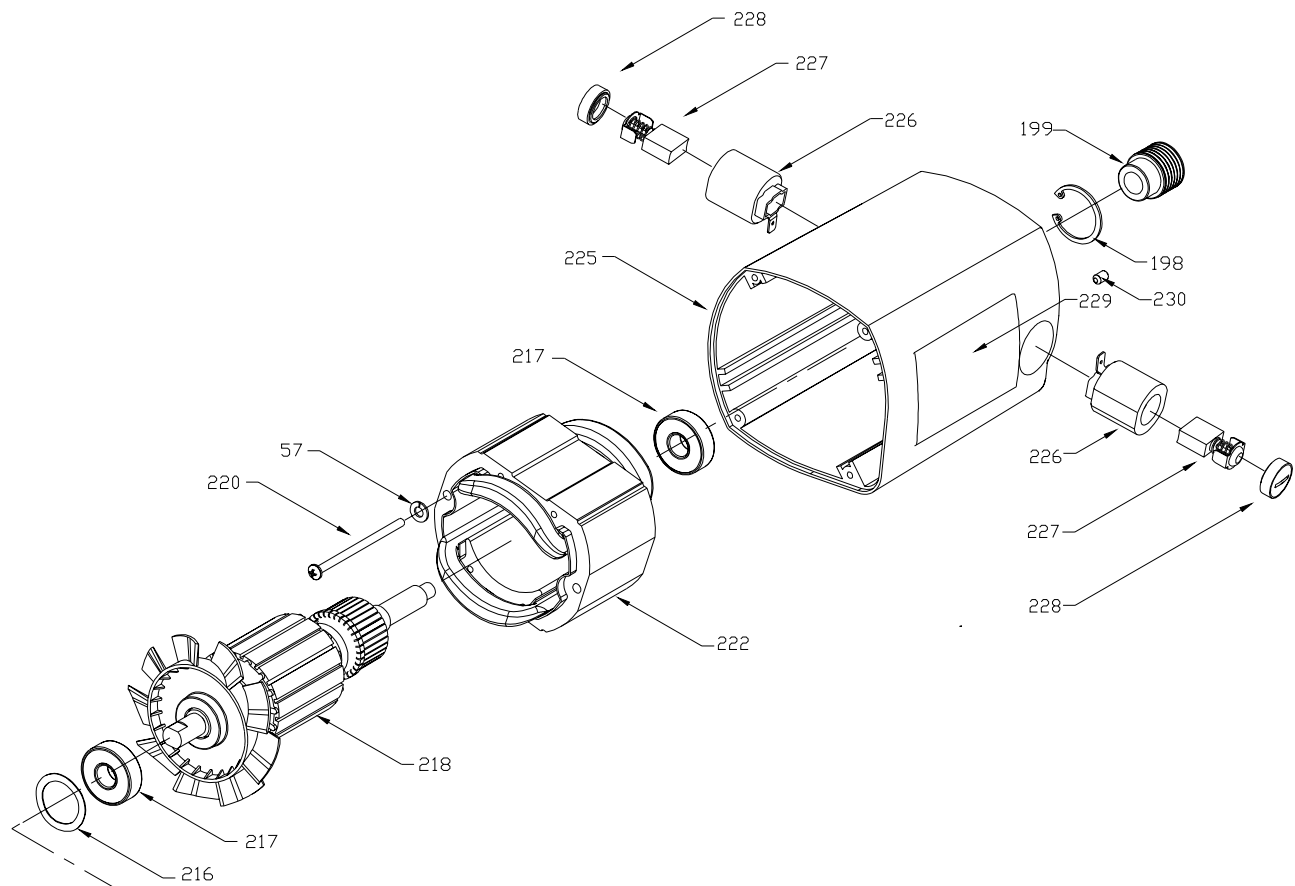

REPLACEMENT PARTS

<u>Ref.</u>	<u>No.</u>	<u>Part No.</u>	<u>Description</u>
*		903443	MOTOR ASSY
	57	1343538	WASHER
	99	899343	LABEL
	107	1342455	M5 X .8 X 10 SCREW
	135	899317	CUSHION
	150	1320101	WASHER
	198	1246195	RETAINING RING
	199	1343873	MOTOR PULLEY
	200	902019	M5X0.8X16 SCREW
	201	1345695	CORD CLAMP, SEE NOTE A
	203	899361	SWITCH HOUSING
	205	903884	WASHER
	207	899362	SWITCH COVER
	208	899363	M4 X 1.75 X 12MM SCREW
	209	903981	SWITCH
	210	1344601	SWITCH PADDLE
	212	1343051	M4.2 X 20 SCREW
	213	1243525	WASHER
	215	899365	MOTOR END CAP
	216	1343929	WASHER
	217	920-04-013-104	BEARING
	218	901030	ARMATURE
	220	1343932	M4.8 X 72MM SCREW
	222	903097	FIELD
	225	899366	MOTOR HOUSING
	226	1343934	BRUSH HOLDER
	227	n 1313113	BRUSH
	228	1343936	BRUSH CAP
	229	899367	NAMEPLATE
	230	1246137	M5 X .8 X 8 SCREW
	236	903098	MOTOR CORD
	**	999-02-023-1214	GREASE
			ACCESSORIES: (Optional)
	**	50-446	DUST CHUTE
	*		NOT SHOWN ASSEMBLED
	**		NOT SHOWN

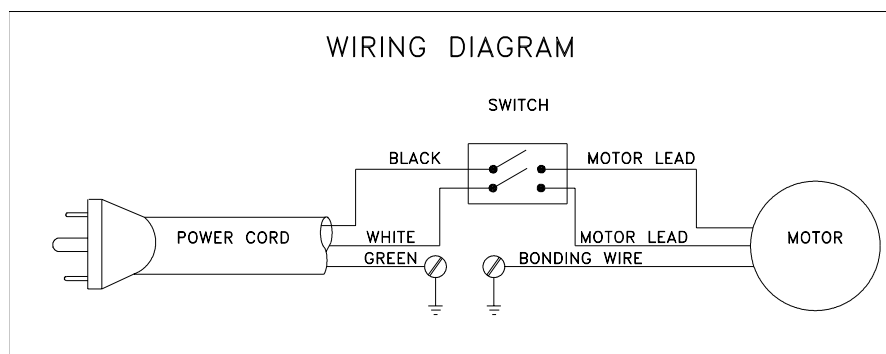

SERVICE NOTES:

A - This part has "14 AWG" and "16 AWG" molded into either side (reading from screw hole to screw hole). Be sure to put the correct side down when replacing this part. Example: 14 AWG is molded onto the side that faces down against a 14 AWG cord. The protruding ridges on the 16 AWG side are about twice the height, but with a smaller radius of the 14 AWG.

STANDARD SAFETY EQUIPMENT

In order to promote tool safety, Delta Machinery strictly enforces the policy of repairing or replacing any damaged or missing standard safety equipment on machines presented to Delta Authorized Service Centers for service/repairs. Any product that is presented to a Delta Authorized Service Centers for repairs which contains missing or damaged standard safety equipment will have that equipment repaired or replaced and the customer will be charged for any such service/repairs. Customers can avoid such charges only if the missing safety component is supplied to the service center at the time of repair.

This parts list is provided to aid in obtaining service parts. Copies of the instruction and maintenance literature can be obtained through the Delta Technical Publications Department or through your service outlet.